

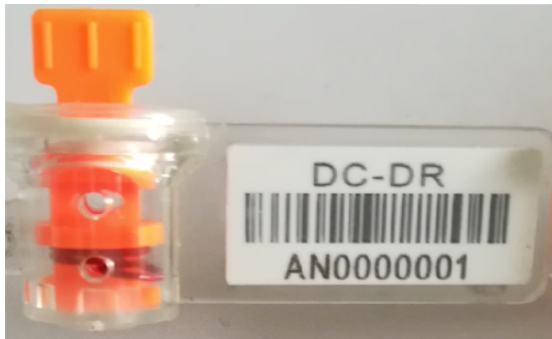

CS TWIST SEAL

PC Adjustable Plastic Seal with Stainless Steel Wire



APPLICATIONS

- Electric Meters
- ATM Cassettes
- Zippered Money Bags
- Fiber Drums
- Valves
- Tank Trucks
- Mini-Bars /Liquor Kits
- Measuring Devices
- Scales
- Pouches
- Tote Boxes
- Vending Machines

FEATURES

- Suitable for a wide range of applications
- 3 parts body and welding cover on flag makes it very high security seal
- PC body with UV resistant additive gives to this seal a long lasting life span under severe conditions
- Internal insert with glowing feature under UV light (Optional)
- White panel with glowing feature under UV light (Optional)
- Stainless Steel wire 304 with 7 strands, makes it very flexible
- 0.7mm wire diameter fits small sealing apertures
- Matted format: 5 pieces per matt.
- Easy to install
- 4 points ratch on twisting mechanism
- Customized Logo on back of Flag (Optional)

MATERIAL

- Polycarbonate body + insert
- Stainless Steel wire 304
- ABS crown

Technical Drawings

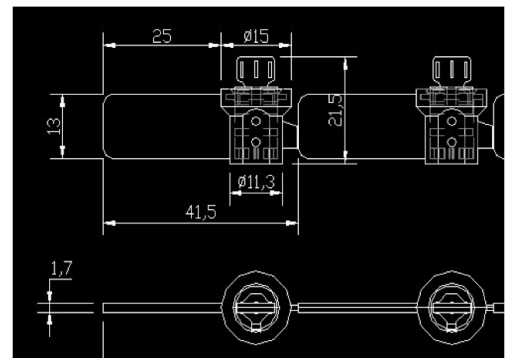

DECORATION & PRINTING

- Laser printing directly on flag and body
- White panel on flag ultrasonic welded for decoration and customization with laser printer
- Customized with your logo as part of the flag as part of mould (Optional)
- Logo + 09 alphanumeric characters + bar code with 9 characters
- Embossed DC-DR + AL TSA + CTY letters on bottom of body as part of mould.
- 7 last numbers on top of Crown as a security measure.

Part No.

- SKLMS004-X (Laser printed on White panel)
- SKLMS004-IDX (Logo on back of White panel as part of mould)

Patent Nos.: Pending

CATHAY SEAL PTE. LTD
Blk 167 Jalan Bukit Merah , #05-12 (SR11) Tower 4
Singapore 150167
Tel/Fax: +65 6274 4041